



Service Manual

Type EL

Table of Contents

Cleaning or replacement of the filter elementSection 1

Replacement of the diaphragm holder and the valve box.....Section 2

Replacement of the Magnet.....Section 3

Reset of the Auto Stopper.....Section 4

EL-60, 80-15

EL-80-17, 100

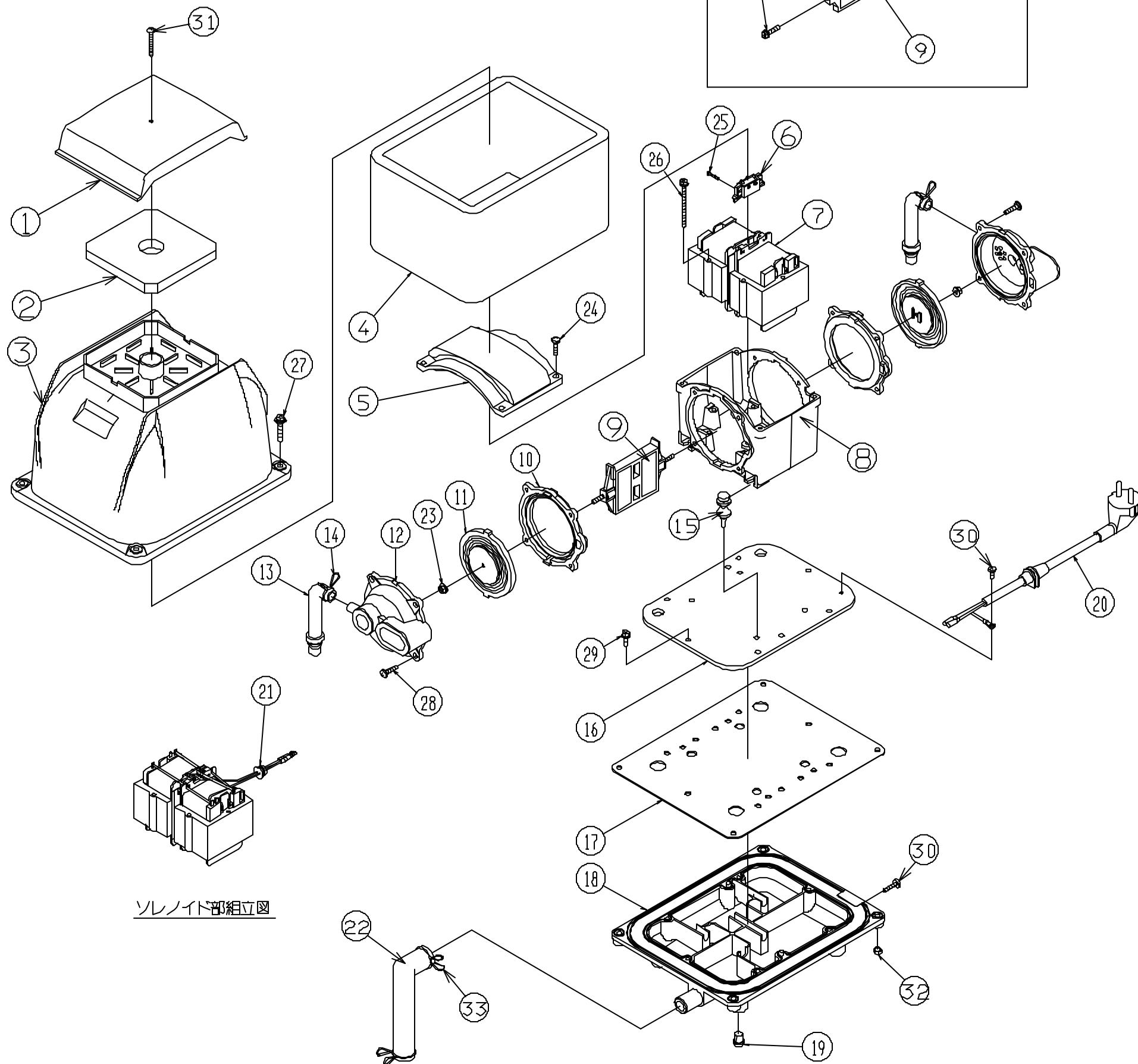

ソレノイド部組立図

33	Hose Band
32	Hexagonal nut
24~31	Screw
23	Hexagonal nut (EL-60, 80-15), Screw (EL-80-17, 100)
22	L-Type Air Supply Hose
21	Lead-in Wire Bush
20	Power Supply Cord
19	Rubber Foot
18	Tank Base
17	Tank Base Packing
16	Tank Base Cover
15	Vibration Isolating Rubber
14	Hose Band
13	Connecting Pipe
12	Valve Box
11	Diaphragm
10	Diaphragm Holder
9	Magnet
8	Solenoid Holder
7	Solenoid
6	Auto Stopper
5	Holder Cover
4	Shock Absorber
3	Overall Cover
2	Filter Element
1	Filter Cover

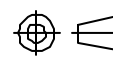
No.	部品名称						
	FD No.	G009	作成日	01.4.2	型式	EL-60~100	
	承認	検図	設計	製図	式名	CE marking	
尺 寸	FREE				図 名	部品展開図	
世晃産業株式会社						図 番	ZE30102
						REV.	0



Disconnect the power supply before attempting to service the pump.

1. Cleaning or replacement of the filter element



A. Remove screw (31) from the filter cover.



B. Remove the filter cover (1) from the overall cover (3).



C. Shake out dust from the filter element (2). If the filter element is heavily soiled, then wash in mild soapy water and let it dry completely. Replace the filter if it has deteriorated.

2. Replacement of the diaphragm holder, the diaphragm, and the valve box



A. Remove the 4 exterior bolts (27)



B. Remove the overall cover (3).

2. Replacement of the diaphragm holder, the diaphragm, and the valve box (Continued)



C. Remove sound attenuating material (4).



D. Remove 4 screws (24).



E. Remove holder cover (5).



F. Remove 4 screws (28).



G. Disconnect connecting Pipe (13)



H. Remove the valve box (12).

TIP

If it is difficult to remove the valve box (12) from the diaphragm holder (10), then use a screw driver to pry apart.

2. Replacement of the diaphragm holder, the diaphragm, and the valve box (Continued)

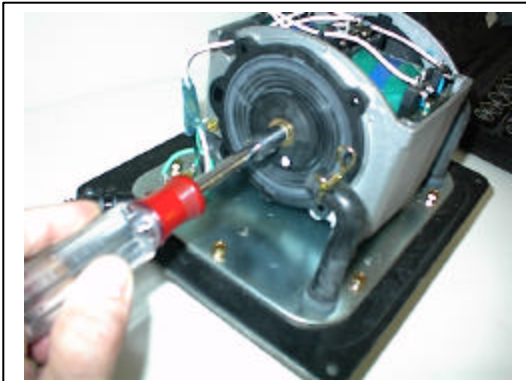

I. Remove hex nut (23).



J. Remove diaphragm holder (11).

K. Replace the diaphragm holder with new diaphragm holder and replace the valve box with a new valve box.

3. Replacement of the magnet

A. Complete steps A-J in section 2



B. Remove the diaphragm holder (10) and the magnet (9) after opposite diaphragm holder (10) has been removed.



C. Remove hex nut (29).

D. Replace magnet (9) with a new magnet making sure that the new magnet is in the correct orientation. The bumper tabs that contain the autostop device should be in the up position.

E. Make sure that the magnet (9) does not come in contact with the solenoid (7).

4. Resetting the Auto-stopper

A. Reassemble steps J-H in section 2

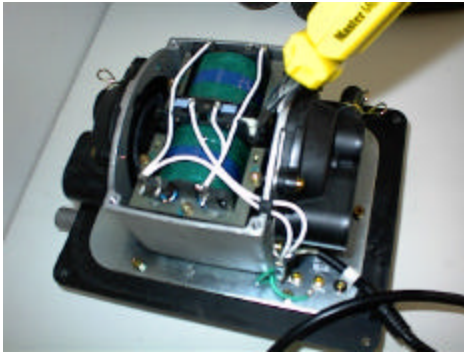

B. Center the slider in the middle position with a screwdriver.

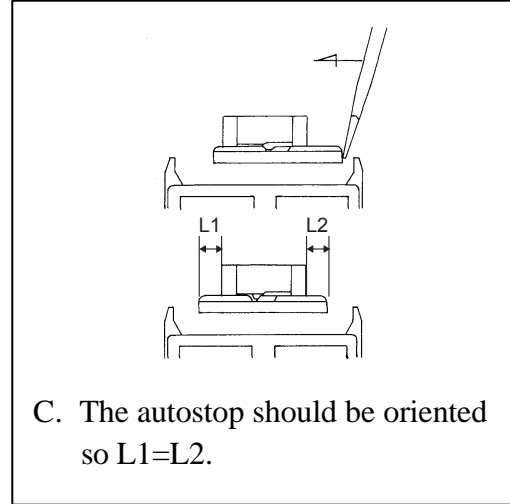

C. The autostop should be oriented so $L1=L2$.

D. Reassemble pump by reversing steps J-A in section 2.

Warning!

Never touch live parts as electric shock will occur!